



## Filter for Removing Dust and Drain in Compressed Air Air Filter

- *Filter for Drain and Dust (Filtering Accuracy: 5 $\mu$ m)*
- *Resin-made Bowl Guard which does not corrode.*
- *Two Drainage Methods: Manual or Auto Draining*

## Air Filter

### Model Designation (Example)

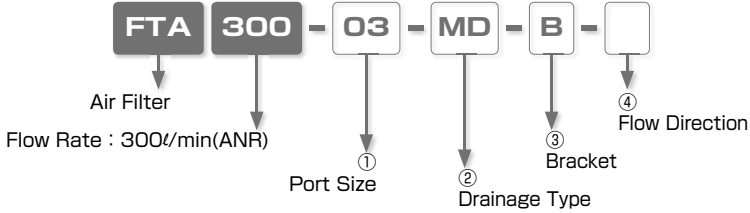

#### ① Port Size

02 : Rc1/4(Taper Pipe Female Thread)

03 : Rc3/8(Taper Pipe Female Thread)

#### ② Drainage Type

MD : Manual Drain

AD : Auto Drain

#### ③ Fixing Bracket

No Code : Without Bracket

B : With Bracket

#### ④ Flow Direction

No Code : Left to Right

R : Right to Left

### Specifications

| Model Code              | FTA300-□-MD              |            | FTA300-□-AD        |            |
|-------------------------|--------------------------|------------|--------------------|------------|
| Port Dia.               | Rc1/4 (02)               | Rc3/8 (03) | Rc1/4 (02)         | Rc3/8 (03) |
| Fluid Medium            | Air                      |            |                    |            |
| Max. Operating Pressure | 145psi (1MPa)            |            |                    |            |
| Min. Operating Pressure | 7.25psi (0.05MPa)        |            | 21.75psi (0.15MPa) |            |
| Pressure Resistance     | 217psi (1.5MPa)          |            |                    |            |
| Operating Temp. Range   | 41~122°F (5~50°C)        |            |                    |            |
| Filtering Accuracy      | 5μm                      |            |                    |            |
| Bowl Capacity           | 1.83 cubic inches (30cc) |            |                    | —          |

### Construction

Symbol of Manual Drain

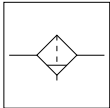

Symbol of Auto Drain

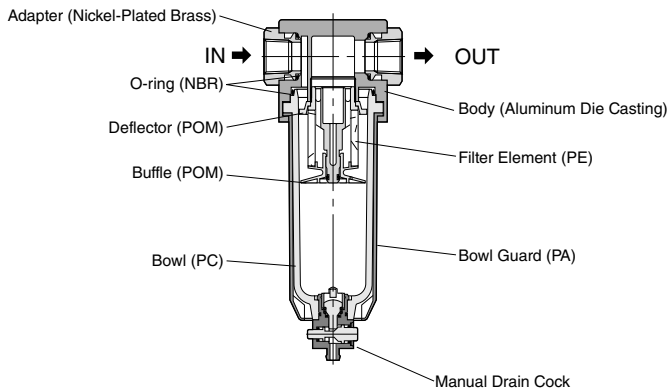
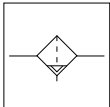

# FTA Air Filter

RoHS compliant

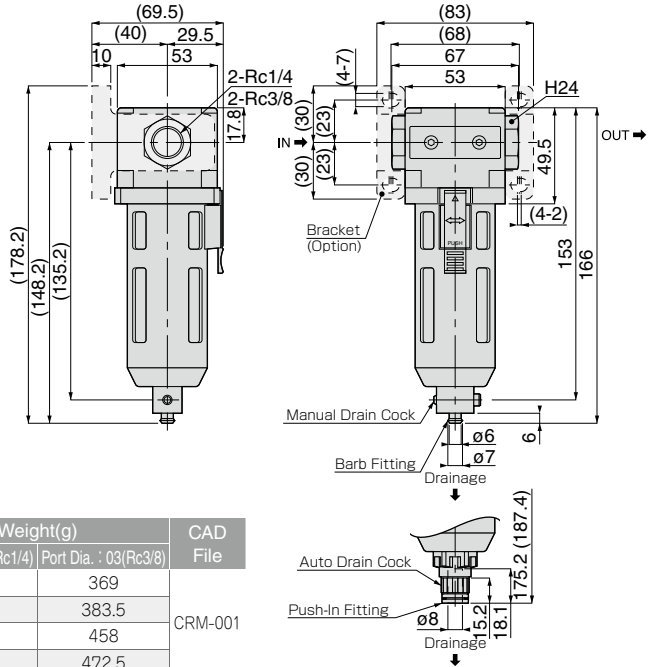

| Model Code      | Weight(g)             |                       | CAD File |
|-----------------|-----------------------|-----------------------|----------|
|                 | Port Dia. : 02(Rc1/4) | Port Dia. : 03(Rc3/8) |          |
| FTA300-□-MD-□   | 390                   | 369                   | CRM-001  |
| FTA300-□-AD-□   | 404.5                 | 383.5                 |          |
| FTA300-□-MD-B-□ | 465                   | 458                   |          |
| FTA300-□-AD-B-□ | 479.5                 | 472.5                 |          |

\* Fill in □ on left with "02" for Rc1/4 or "03" for Rc 3/8.

Fill in the end □ with "R" for the flow direction from right to left. Leave the end □ blank when the direction is from left to right.

\* Dimension in ( ) shows the dimension when the bracket is installed.

## Characteristics

Flow Characteristics

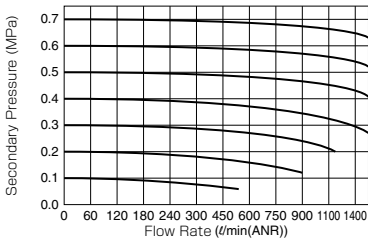

## △ Detailed Safety Instructions

Before using PISCO products, be sure to read "Safety Instructions" and "Safety Instruction Manual" and Common Safety Instructions for Modular Filter and Regulator Unit".



## Filter for Removing Dust and Oil Mist in Compressed Air Mist Filter

- *Filter for Drain and Oil Mist (Filtering Accuracy: 0.3 $\mu$ m)*
- *Resin-made Bowl Guard which does not corrode.*
- *Two Drainage Methods: Manual or Auto Draining*

## Mist Filter

### Model Designation (Example)

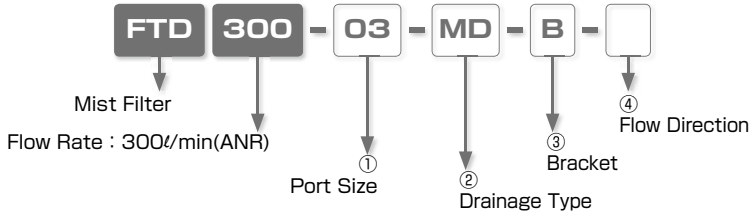

#### ① Port Size

02 : Rc1/4(Taper Pipe Female Thread)

03 : Rc3/8(Taper Pipe Female Thread)

#### ② Drainage Type

MD : Manual Drain

AD : Auto Drain

#### ③ Bracket

No Code : without Bracket

B : with Bracket

#### ④ Flow Direction

No Code : Left to Right

R : Right to Left

### Specifications

| Model Code              | FTD300- □ -MD                       |            | FTD300- □ -AD      |            |
|-------------------------|-------------------------------------|------------|--------------------|------------|
| Port Dia.               | Rc1/4 (02)                          | Rc3/8 (03) | Rc1/4 (02)         | Rc3/8 (03) |
| Fluid Medium            | Air                                 |            |                    |            |
| Max. Operating Pressure | 145psi (1MPa)                       |            |                    |            |
| Min. Operating Pressure | 7.25psi (0.05MPa)                   |            | 21.75psi (0.15MPa) |            |
| Pressure Resistance     | 217psi (1.5MPa)                     |            |                    |            |
| Operating Temp. Range   | 41~ 122°F (5 ~ 50°C)                |            |                    |            |
| Filtering Accuracy      | 0.3μm (Collecting Efficiency : 99%) |            |                    |            |
| Bawl Capacity           | 1.83 cubic inches (30cc)            |            | -                  |            |

### Construction

Symbol of Manual Drain

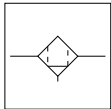

Symbol of Auto Drain

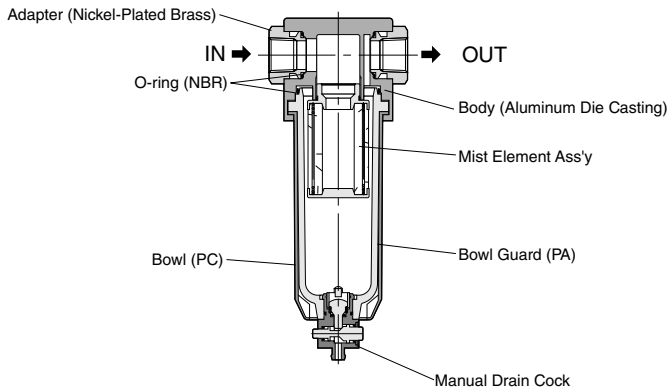
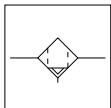

# FTD Mist Filter

RoHS compliant

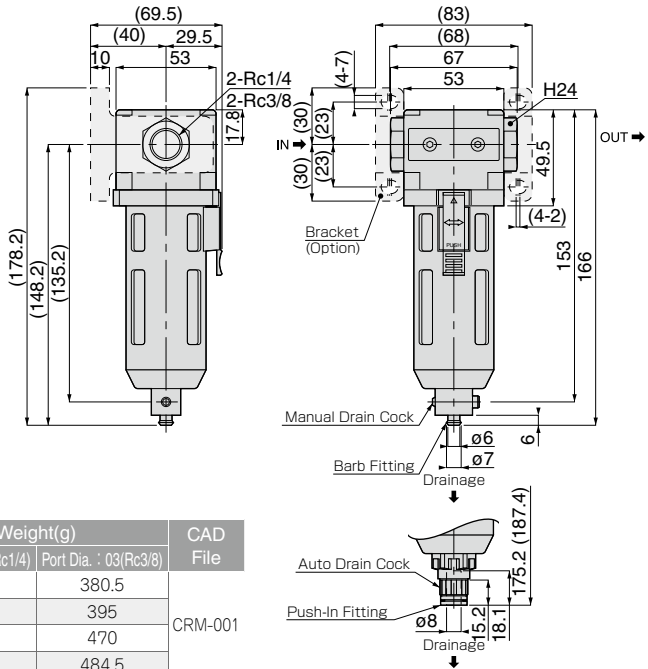

| Model Code      | Weight(g)             |                       | CAD File |
|-----------------|-----------------------|-----------------------|----------|
|                 | Port Dia. : 02(Rc1/4) | Port Dia. : 03(Rc3/8) |          |
| FTD300-□-MD-□   | 401.5                 | 380.5                 | CRM-001  |
| FTD300-□-AD-□   | 416                   | 395                   |          |
| FTD300-□-MD-B-□ | 477                   | 470                   |          |
| FTD300-□-AD-B-□ | 491.5                 | 484.5                 |          |

\* Fill in □ on left with "02" for Rc1/4 or "03" for Rc3/8.

Fill in the end □ with "R" for the flow direction from right to left. Leave the end □ blank when the direction is from left to right.

\* Dimension in ( ) shows the dimension when the bracket is installed.

## Characteristics

Flow Characteristics

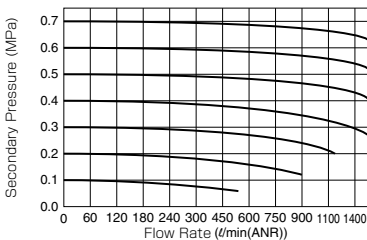

## △ Detailed Safety Instructions

Before using PISCO products, be sure to read "Safety Instructions" and "Safety Instruction Manual" and Common Safety Instructions for Modular Filter and Regulator Unit.



## Filter for Removing Tiny Dust and Oil Mist in Compressed Air **Micromist Filter**

- *Filter for Tiny Dust and Oil Mist (Filtering Accuracy: 0.01 $\mu$ m)*
- *Resin-made Bowl Guard which does not corrode.*
- *Two Drainage Methods: Manual or Auto Draining*

## Micromist Filter

### Model Designation (Example)

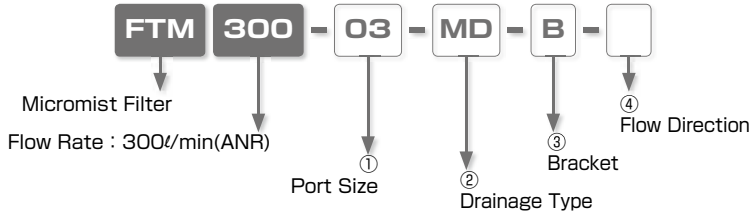

#### ① Port Size

02 : Rc1/4(Taper Pipe Female Thread)

03 : Rc3/8(Taper Pipe Female Thread)

#### ② Drainage Type

MD : Manual Drain

AD : Auto Drain

#### ③ Bracket

No Code : without Bracket

B : with Bracket

#### ④ Flow Direction

No Code : Left to Right

R : Right to Left

### Specifications

| Model Code              | FTM300- <input type="checkbox"/> -MD |            | FTM300- <input type="checkbox"/> -AD |            |
|-------------------------|--------------------------------------|------------|--------------------------------------|------------|
| Port Dia.               | Rc1/4 (02)                           | Rc3/8 (03) | Rc1/4 (02)                           | Rc3/8 (03) |
| Fluid Medium            | Air                                  |            |                                      |            |
| Max. Operating Pressure | 145psi (1MPa)                        |            |                                      |            |
| Min. Operating Pressure | 7.25psi (0.05MPa)                    |            | 21.75psi (0.15MPa)                   |            |
| Pressure Resistance     | 217psi (1.5MPa)                      |            |                                      |            |
| Operating Temp. Range   | 41~122°F (5~50°C)                    |            |                                      |            |
| Filtering Accuracy      | 0.01μm (Collecting Efficiency : 99%) |            |                                      |            |
| Bowl Capacity           | 1.83 cubic inches (30cc)             |            | —                                    |            |

### Construction

Symbol of Manual Drain

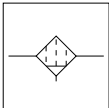

Symbol of Auto Drain

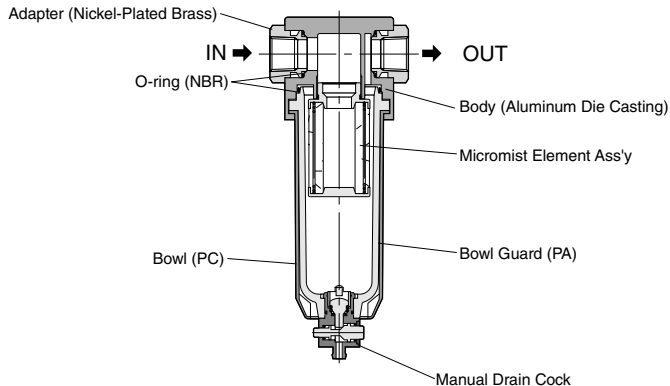
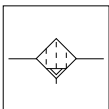



# FTM Micromist Filter

RoHS compliant

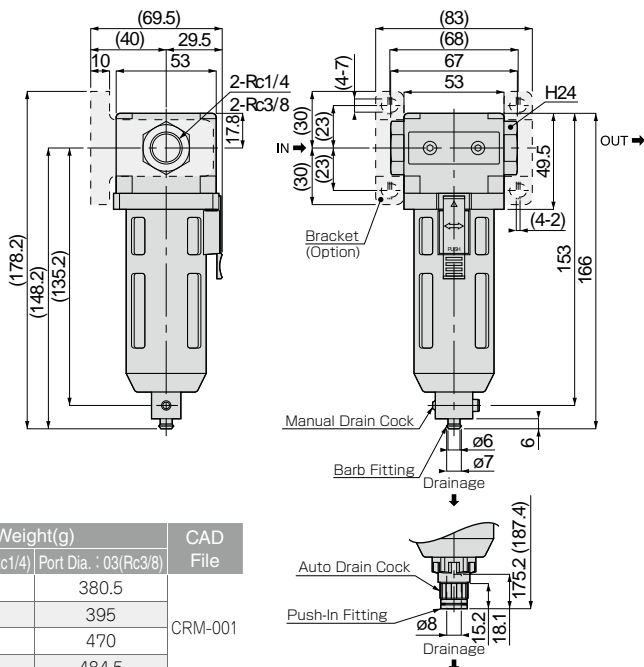

| Model Code      | Weight(g)             |                       | CAD File |
|-----------------|-----------------------|-----------------------|----------|
|                 | Port Dia. : 02(Rc1/4) | Port Dia. : 03(Rc3/8) |          |
| FTM300-□-MD-□   | 401.5                 | 380.5                 | CRM-001  |
| FTM300-□-AD-□   | 416                   | 395                   |          |
| FTM300-□-MD-B-□ | 477                   | 470                   |          |
| FTM300-□-AD-B-□ | 491.5                 | 484.5                 |          |

\* Fill in □ on left with "02" for Rc1/4 or "03" for Rc3/8.  
 Fill in the end □ with "R" for the flow direction from right to left. Leave the end □ blank when the direction is from left to right.  
 \* Dimension in ( ) shows the dimension when the bracket is installed.

## Characteristics

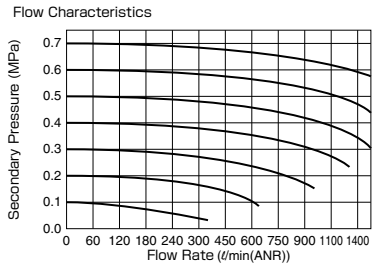

## △ Detailed Safety Instructions

Before using PISCO products, be sure to read "Safety Instructions" and "Safety Instruction Manual" and Common Safety Instructions for Modular Filter and Regulator Unit".



## ⚠ Safety Rules for Use

### 1. Installation and Piping

- Make sure to remove oils such as machining oil and carry out enough flushing before installation.
- Place the drain cock downward and vertically at the installation of Filter, Mist Filter, Micromist Filter and Filter Regulator.

### 2. Atmosphere and Environment

- Avoid using or storing the product where it is exposed to sunshine, rain or water.
- Bowl material of Filter, Mist Filter, Micromist Filter and Filter Regulator is polycarbonate. Avoid using the product with the chemicals on page 255 or in the atmosphere of the chemicals.

### 3. Maintenance and Inspection

- Use a neutral detergent to wash the plastic bowl. Avoid using alcohol or thinner to wash.
- 5 $\mu$ m element is reusable after washing it with a neutral detergent, but 0.3 and 0.01 elements are not.
- Pressure drop to 0.07MPa is an indication of element life. Wash the element or replace it to new one.

### 4. Drainage

#### 4-1. Manual Drain Cock

- Drain is discharged in the following cases.
  - ① By manual operation of push button.
  - ② When the internal pressure in pipe becomes zero.
- For drainage piping, use tube with bore  $\varnothing$ 6mm. Avoid rising piping within 5 m length.
- Air comes out from the drain port until the pressure reaches up to 0.05MPa. This is not a malfunction.

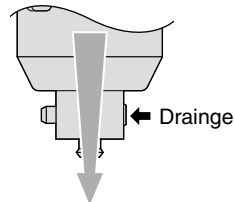

#### 4-2. Auto Drain Cock

- Drain is discharged in the following cases.
  - ① Manual operation of the screw type drain cock.
  - ② Certain amount of drain is stored.
  - ③ Internal pressure in pipe becomes zero.
- Use tube with O. D.  $\varnothing$ 8mm. Avoid rising piping within 5 m length.
- Air comes out from the drain port until the pressure reaches up to 0.15MPa. This is not a malfunction.

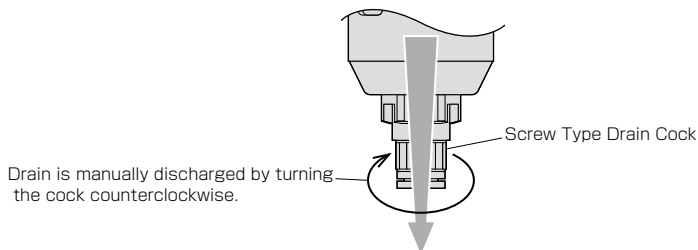



## 2) 0.3 and 0.01 $\mu$ m Element (FTD300-□-□D, FTM300-□-□D)

Replacement method is different by each element.

(1) For Filter Element Set "FE300DK (for 0.3 $\mu$ m)" or "FE300MK (for 0.01 $\mu$ m)"

(There is a cross recessed pan head screw on the bottom of filter element)

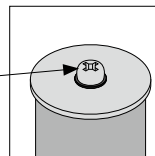

- ① Detach the filter element set by untightening the cross recessed pan head screw. (When the screw guide remains of the body, go to ③)
- ② Remove the screw from the screw guide.
- ③ Detach the element
- ④ If the screw guide is detached when detaching the filter element set, place the guide on the body.
- ⑤ Place a new filter element on the screw guide.
- ⑥ Place in the order of Gasket, Cap Guide and Link on the cross recessed pan head screw. No projection side of Cap Guide needs to face Gasket side.
- ⑦ Tighten the screw guide with the filter element which was mentioned in ⑥ by the cross recessed pan head screw. Recommended tightening torque is 0.9-1.1Nm.

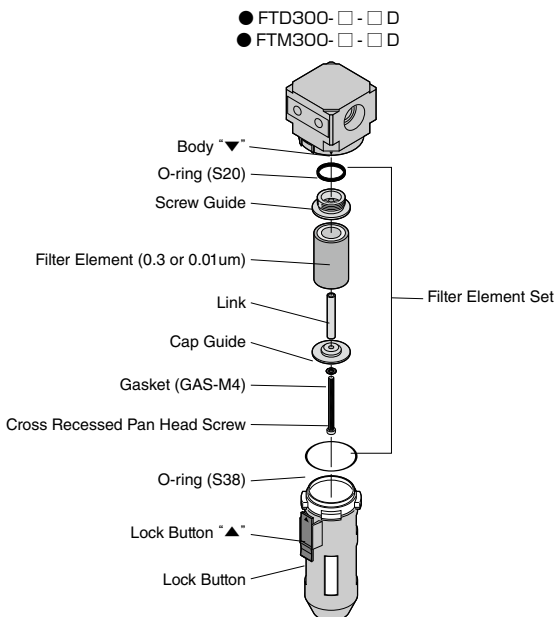

(2) For Filter Element Set "FE300D (for 0.3 $\mu$ m)" or "FE300M (for 0.01 $\mu$ m)"

(There is no Cross Recessed Pan Head Screw on the bottom of filter element)

- ① At the first replacement, Detach FE300D or FE300M from the body and replace it to FE300DK or FE300MK
- ② After the second time of replacement, follow the replacement instruction for "FE300DK" or "FE300MK". Replacement of FE300DN or FE300MN (Filter Element) only is necessary.

## 5. Attachment / Detachment of Bowl and Filter Replacement

### 5-1. Attaching and Detaching Method of Bowl (Refer to the below figures)

#### ① Detachment of Bowl

Turn a bowl guard during pushing a lock button. When the lock button marking "▲" faces the body marking "▼", the bowl is detachable.

Note) Make sure that there is no internal pressure in the bowl before detaching.

#### ② Attachment of Bowl

Face the marking "▲" on the lock button and "▼" on the product body first. Push the bowl guard into the body completely and turn the guard to fix the lock button on the groove in the body.

Note) Make sure that the bowl is properly fixed before applying pressure.

#### ① Detachment of Bowl

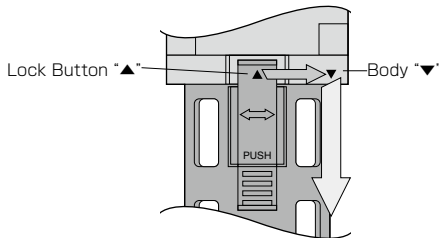

#### ② Attachment of Bowl

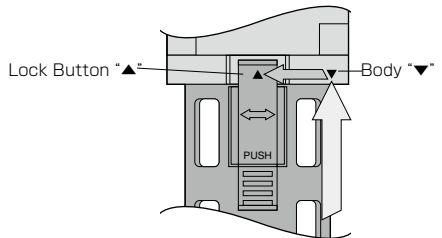

### 5-2. Filter Replacement (Refer to figures)

#### 1) 5μm Element (FTA300-□-□D)

● FTA300-□-□D

#### ① Detachment of O-ring

Take off O-ring placed on the center of baffle with tweezers.

#### ② Detachment of Baffle

Remove the baffle. (Due to the structure, it is fixed tightly)

#### ③ Detachment of Element

#### ④ Wash element or replace it

#### ⑤ Attachment of Baffle

Push the baffle until clicking noise sounds.

#### ⑥ Attachment of O-ring

Place O-ring in the center of baffle.

Note) Replace O-ring to a new one.

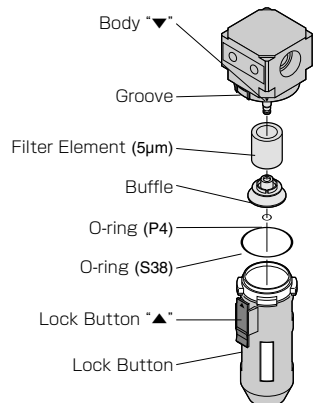



## List of Chemical Resistance (Do not use the product under the following chemical atmosphere)

| Chemical Type      | Classification   | Chemicals   | Applications  |
|--------------------|--|---|---|
| Inorganic Compound | Acid   | Hydrochloric Acid, Sulfuric Acid, Nitric Acid, Fluorine, Phosphoric Acid, Chromic Acid and etc.   | Metal picking solution, acid degreasing solution, skin repair solution and etc.   |
|                    | Alkali   | Caustic Soda, Caustic Potash, Slaked Lime, Aqueous Ammonia, Washing Soda and other Alkali Materials   | Alkaline degreasing solution for metals   |
| Organic Compound   | Inorganic Salt   | Sodium Sulphide, Potassium Nitrate, Potassium Dichromate, Sodium Nitrate and etc.   |   |
|                    | Aromatic Hydrocarbon   | Benzene, Toluene, Xylene, Ethylbenzene, Styrene and etc.  | Contained in painting thinner (Benzene, Toluene and Xylene)   |
|                    | Chlorinated Aliphatic Hydrocarbon                                      | Methyl Chloride, Ethylene Chloride, Methylene Chloride, Acetylene Chloride, Chloroform, Trichloroethylene, Berkelene, Carbon Tetrachloride and etc. | Organic solvent solution for metals (Trichloroethylene, Berkeleneand Carbon Tetrachloride)                                  |
|                    | Chlorinated Aromatic Hydrocarbon                                       | Chlorobenzene, Dichlorobenzene, Benzene Hexachloride (BHC) and etc.   | Agricultural Chemicals  |
|                    | Petroleum Components   | Solvent, Naphtha and Gasoline   |   |
|                    | Alcohol  | Methyl Alcohol, Ethyl Alcohol, Cyclohexanol and Benzyl alcohol  | Used as an anti-freezing agent  |
|                    | Fenol  | Carbolic Acid, Cresol, Naphthol and etc.  | Disinfectant  |
|                    | Ether  | Methyl Ether, Ethyl Methyl Ether and Ethyl Ether  | Break fluid additives   |
|                    | Ketone   | Acetone, Methyl Ethyl Ketone, Cyclohexanone, Acetophenon and etc.   |   |
|                    | Carboxylic Acid  | Formic Acid, Acetic Acid, Butylic Acid, Acrylic Acid, Oxalic Acid, Phthalic Acid and etc.   | Dyeing agent and oxalic acid are used for aluminum repairing agent. Phthalic acid is used for base of paint.                |
|                    | Phosphate  | Dimethyl Phthalate (DMP), Diethyl Phthalate (DEP), Dibutyl Phthalate (DBP) and Dioctyl Phthalate (DOP)  | Used as additives of lubricant, synthetic hydraulic fluid or rust inhibitor. Also used as plasticizer for synthetic resins. |
|                    | Oxo Acid   | Glycolic Acid, Lactic Acid, Malic Acid, Citric Acid and Tartaric Acid   |   |
|                    | Nitro Compound   | Nitromethane, Nitroethane, Nitroethylene, Nitrobenzene and etc.   |   |
|                    | Amine  | Methyl Amine, Dimethyl Amine, Ethylamines, Aniline, Acetaniline and etc.  | Break fluid additives   |
| Nitrile            | Acetonitrile, Acrylonitrile, Benzonitrile, aceto(iso) nitrile and etc. | Material of nitrile rubber  |   |



### Common Safety Instructions for Modular Type Filter and Regulator Unit

Before selecting or using PISCO products, read the following instructions. Read the detailed instructions for individual series.

#### Warning

1. When installing the dryer, provide adequate support and fix it securely. Looseness or dropping off of the dryer may cause injuries.
2. Do not use the dryer without the explosion-proof casing (bowl guard). If the bowl breaks, the pieces may fly apart to cause injuries.
3. Make sure to set the lock lever on the filter, mist filter and micromist filter to "lock" before using. Otherwise, there is a risk of Bowl Guard or Bowl coming off which may cause injuries.
4. When conducting the maintenance, checkup, or replacement of the product, make sure to turn off the power and shut off the air supply. Confirm the residual pressure in the piping becomes zero before maintenance or replacement of expendables.
5. Do not use the dryer in a fluid or atmosphere containing corrosive gas or organic solvent gas. Such a use may deteriorate the dryer body which causes leakage or damage.

#### Caution

1. Air Filter, Mist filter and Micromist Filter shall be installed downward in a vertical direction. Improper installation may cause faulty draining.
2. Drain in Air Filter, Mist Filter and Micromist Filter are discharged automatically at the air pressure less than 0.05MPa for the manual drain type and 0.15MPa for the auto drain type. When installing, consider the self-discharging of air and drain.
3. When the manual drain type is selected, discharge drain before it reaches to the "MAX. DRAIN LEVEL" . Otherwise, it may become the cause which the drain flows into a secondary side.
4. Check the IN side of air supply by the  $\triangleright$  mark. Wrong piping may impair the performance.
5. Do not apply the pressure beyond the pressure setting range (Max. 0.85MPa) for Regulator. Otherwise, there is a risk of malfunctions.

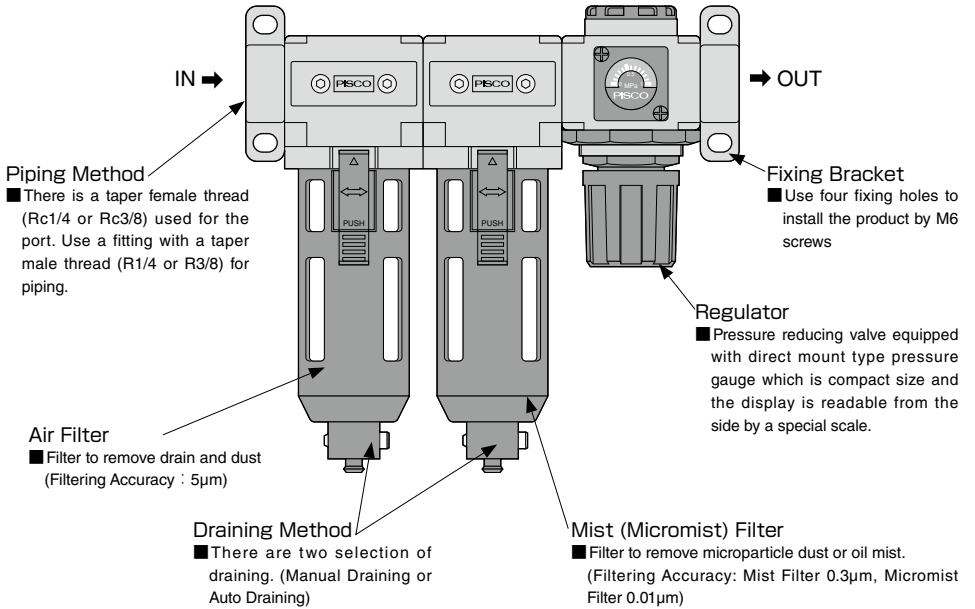



# SAFETY Instructions

This safety instructions aim to prevent personal injury and damage to properties by requiring proper use of PISCO products.

Be certain to follow ISO 4414 and JIS B 8370

ISO 4414 : Pneumatic fluid power...Recommendations for the application of equipment to transmission and control systems.

JIS B 8370 : General rules and safety requirements for systems and their components.

This safety instructions is classified into "Danger", "Warning" and "Caution" depending on the degree of danger or damages caused by improper use of PISCO products.



**Danger**

Hazardous conditions. It can cause death or serious personal injury.



**Warning**

Hazardous conditions depending on usages. Improper use of PISCO products can cause death or serious personal injury.



**Caution**

Hazardous conditions depending on usages. Improper use of PISCO products can cause personal injury or damages to properties.



## Warning

### 1. Selection of pneumatic products

- ① A user who is a pneumatic system designer or has sufficient experience and technical expertise should select PISCO products.
- ② Due to wide variety of operating conditions and applications for PISCO products, carry out the analysis and evaluation on PISCO products. The pneumatic system designer is solely responsible for assuring that the user's requirements are met and that the application presents no health or safety hazards. All designers are required to fully understand the specifications of PISCO products and constitute all systems based on the latest catalog or information, considering any malfunctions.

### 2. Handle the pneumatic equipment with enough knowledge and experience

- ① Improper use of compressed air is dangerous. Assembly, operation and maintenance of machines using pneumatic equipment should be conducted by a person with enough knowledge and experience.

### 3. Do not operate machine / equipment or remove pneumatic equipment until safety is confirmed.

- ① Make sure that preventive measures against falling work-pieces or sudden movements of machine are completed before inspection or maintenance of these machine.
- ② Make sure the above preventive measures are completed. A compressed air supply and the power supply to the machine must be off, and also the compressed air in the systems must be exhausted.
- ③ Restart the machines with care after ensuring to take all preventive measures against sudden movements.



## Disclaimer

1. PISCO does not take any responsibility for any incidental or indirect loss, such as production line stop, interruption of business, loss of benefits, personal injury, etc., caused by any failure on use or application of PISCO products.
2. PISCO does not take any responsibility for any loss caused by natural disasters, fires not related to PISCO products, acts by third parties, and intentional or accidental damages of PISCO products due to incorrect usage.
3. PISCO does not take any responsibility for any loss caused by improper usage of PISCO products such as exceeding the specification limit or not following the usage the published instructions and catalog allow.
4. PISCO does not take any responsibility for any loss caused by remodeling of PISCO products, or by combinational use with non-PISCO products and other software systems.
5. The damages caused by the defect of Pisco products shall be covered but limited to the full amount of the PISCO products paid by the customer.



# SAFETY INSTRUCTION MANUAL

PISCO products are designed and manufactured for use in general industrial machines. Be sure to read and follow the instructions below.

## ⚠ Danger

1. Do not use PISCO products for the following application
  - ① Equipment used for maintaining / handling human life and body
  - ② Equipment used for moving / transporting human
  - ③ Equipment specifically used for safety purposes

## ⚠ Warning

1. Do not use PISCO products under the following condition
  - ① Beyond the specifications or conditions stated in the catalog, or the instructions.
  - ② Under the direct sunlight or outdoors
  - ③ Excessive vibrations and impacts
  - ④ Exposure / adhere to corrosive gas, inflammable gas, chemicals, seawater, water and vapor. \*  
\* Some products can be used under the condition above(④), refer to the details of specification and condition of each product.
2. Do not disassemble or modify PISCO products, which affect the performance, function, and basic structure of the product.
3. Turn off the power supply, stop the air supply to PISCO products, and make sure there is no residual air pressure in the pipes before maintenance and inspection.
4. Do not touch the release-ring of push-in fitting when there is a working pressure. The lock may be released by the physical contact, and tube may fly out or slip out.
5. Frequent switchover of compressed air may generate heat, and there is a risk of causing burn injury.
6. Avoid any load on PISCO products, such as a tensile strength, twisting and bending. Otherwise, there is a risk of causing damage to the products.
7. As for applications where threads or tubes swing / rotate, use Rotary Joints, High Rotary Joints or Multi-Circuit Rotary Block only. The other PISCO products can be damaged in these applications.
8. Use only Die Temperature Control Fitting Series, Tube Fitting Stainless SUS316 Series, Tube Fitting Stainless SUS316 Compression Fitting Series or Tube Fitting Brass Series under the condition of over 60°C (140° F) water or thermal oil. Other PISCO products can be damaged by heat and hydrolysis under the condition above.
9. As for the condition required to dissipate static electricity or provide an antistatic performance, use EG series fitting and antistatic products only, and do not use other PISCO products. There is a risk that static electricity can cause system defects or failures.
10. Use only Fittings with a characteristic of spatter-proof such as Anti-spatter or Brass series in a place where flame and weld spatter is produced. There is a risk of causing fire by sparks.
11. Turn off the power supply to PISCO products, and make sure there is no residual air pressure in the pipes and equipment before maintenance. Follow the instructions below in order to ensure safety.
  - ① Make sure the safety of all systems related to PISCO products before maintenance.
  - ② Restart of operation after maintenance shall be proceeded with care after ensuring safety of the system by preventive measures against unexpected movements of machines and devices where pneumatic equipment is used.
  - ③ Keep enough space for maintenance when designing a circuit
12. Take safety measures such as providing a protection cover if there is a risk of causing damages or fires on machine / facilities by a fluid leakage.

## ⚠ Caution

1. Remove dusts or drain before piping. They may get into the peripheral machine / facilities and cause malfunction.
2. When inserting an ultra-soft tube into push-in fitting, make sure to place an Insert Ring into the tube edge. There is a risk of causing the escape of tube and a fluid leakage without using an Insert Ring.
3. The product incorporating NBR as seal rubber material has a risk of malfunction caused by ozone crack. Ozone exists in high concentrations in static elimination air, clean-room, and near the high-voltage motors, etc. As a countermeasure, material change from NBR to HNBR or FKM is necessary. Consult with PISCO for more information.
4. Special option "Oil-free" products may cause a very small amount of a fluid leakage. When a fluid medium is liquid or the products are required to be used in harsh environments, contact us for further information.
5. In case of using non-PISCO brand tubes, make sure the tolerance of the outer tube diameter is within the limits of Table 1.

● Table 1. Tube O.D. Tolerance

| mm size | Nylon tube | Polyurethane tube | inch size | Nylon tube | Polyurethane tube |
|---------|------------|-------------------|-----------|------------|-------------------|
| ø1.8mm  | —          | ± 0.05mm          | ø1/8      | ± 0.1mm    | ± 0.15mm          |
| ø3mm    | —          | ± 0.15mm          | ø5/32     | ± 0.1mm    | ± 0.15mm          |
| ø4mm    | ± 0.1mm    | ± 0.15mm          | ø3/16     | ± 0.1mm    | ± 0.15mm          |
| ø6mm    | ± 0.1mm    | ± 0.15mm          | ø1/4      | ± 0.1mm    | ± 0.15mm          |
| ø8mm    | ± 0.1mm    | ± 0.15mm          | ø5/16     | ± 0.1mm    | ± 0.15mm          |
| ø10mm   | ± 0.1mm    | ± 0.15mm          | ø3/8      | ± 0.1mm    | ± 0.15mm          |
| ø12mm   | ± 0.1mm    | ± 0.15mm          | ø1/2      | ± 0.1mm    | ± 0.15mm          |
| ø16mm   | ± 0.1mm    | ± 0.15mm          | ø5/8      | ± 0.1mm    | ± 0.15mm          |

## 6. Instructions for Tube Insertion

- ① Make sure that the cut end surface of the tube is at right angle without a scratch on the surface and deformations.
- ② When inserting a tube, the tube needs to be inserted fully into the push-in fitting until the tubing edge touches the tube end of the fitting as shown in the figure below. Otherwise, there is a risk of leakage.

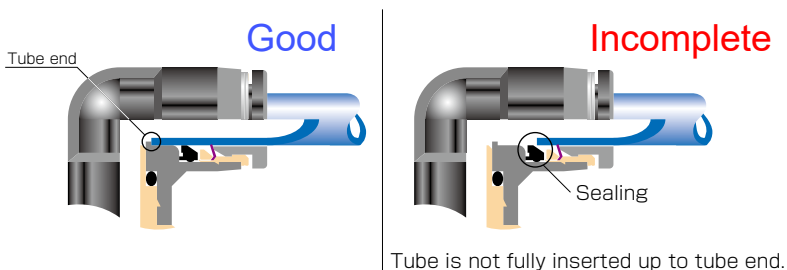

- ③ After inserting the tube, make sure it is inserted properly and not to be disconnected by pulling it moderately.
- ※ When inserting tubes, Lock-claws may be hardly visible in the hole, observed from the front face of the release-ring. But it does not mean the tube will surely escape. Major causes of the tube escape are the followings;
- ① Shear drop of the lock-claws edge
  - ② The problem of tube diameter (usually small)
- Therefore, follow the above instructions from ① to ③, even lock-claws is hardly visible.

7. Instructions for Tube Disconnection

- ① Make sure there is no air pressure inside of the tube, before disconnecting it.
- ② Push the release-ring of the push-in fitting evenly and deeply enough to pull out the tube toward oneself. By insufficient pushing of the release-ring, the tube may not be pulled out or damaged by scratch, and tube shavings may remain inside of the fitting, which may cause the leakage later.

8. Instructions for Installing a fitting

- ① When installing a fitting, use proper tools to tighten a hexagonal-column or an inner hexagonal socket. When inserting a hex key into the inner hexagonal socket of the fitting, be careful so that the tool does not touch lock-claws. The deformation of lock-claws may result in a poor performance of systems or an escape of the tube.
- ② Refer to Table 2 which shows the recommended tightening torque. Do not exceed these limits to tighten a thread. Excessive tightening may break the thread part or deform the gasket and cause a fluid leakage. Tightening thread with tightening torque lower than these limits may cause a loosened thread or a fluid leakage.
- ③ Adjust the tube direction while tightening thread within these limits, since some PISCO products are not rotatable after the installation.

● Table 2: Recommended tightening torque / Sealock color / Gasket materials

| Thread type                | Thread size | Tightening torque | Sealock color | Gasket materials |
|----------------------------|-------------|-------------------|---------------|------------------|
| Metric thread              | M3 × 0.5    | 0.7N·m            | —             | SUS304<br>NBR    |
|                            | M5 × 0.8    | 1.0 ~ 1.5N·m      |               |                  |
|                            | M6 × 1      | 2 ~ 2.7N·m        |               |                  |
|                            | M3 × 0.5    | 0.7N·m            |               | POM              |
|                            | M5 × 0.8    | 1 ~ 1.5N·m        |               |                  |
|                            | M6 × 0.75   | 0.8 ~ 1N·m        |               |                  |
| Taper pipe thread          | M8 × 0.75   | 1 ~ 2N·m          | White         | —                |
|                            | R1/8        | 4.5 ~ 6.5N·m      |               |                  |
|                            | R1/4        | 7 ~ 9N·m          |               |                  |
|                            | R3/8        | 12.5 ~ 14.5N·m    |               |                  |
| Unified thread             | R1/2        | 20 ~ 22N·m        | —             | SUS304, NBR      |
|                            | No.10-32UNF | 1.0 ~ 1.5N·m      |               |                  |
| National pipe thread taper | 1/16-27NPT  | 4.5 ~ 6.5N·m      | White         | —                |
|                            | 1/8-27NPT   | 4.5 ~ 6.5N·m      |               |                  |
|                            | 1/4-18NPT   | 7 ~ 9N·m          |               |                  |
|                            | 3/8-18NPT   | 12.5 ~ 14.5N·m    |               |                  |
|                            | 1/2-14NPT   | 20 ~ 22N·m        |               |                  |

※ These values may differ for some products. Refer to each specification as well.

9. Instructions for removing a fitting

- ① When removing a fitting, use proper tools to loosen a hexagonal-column or an inner hex bolt.
- ② Remove the sealant stuck on the mating equipment. The remained sealant may get into the peripheral equipment and cause malfunctions.

10. Arrange piping avoiding any load on fittings and tubes such as twist, tensile, moment load, shaking and physical impact. These may cause damages to fittings, tube deformations, bursting and the escape of tubes.