



## Suction Cup Equipped with Vacuum Generator Vacuum Pen (Air Pincette)

- *Vacuum sucking pen generates a vacuum and has finger tip control to pick up and release small, delicate components.*
  - *Valve incorporated model "VTB" makes less noise and is energy saving type.*
- *9G8!gUZ*
  - *Anti-static type for applications that are sensitive to ESD static is newly available.*
- *ø1, ø2, ø4, ø6, ø8mm dia. vacuum cups are available as standard.*
- *Specific vacuum headers are provided for vacuum cups of larger sizes. Various cup material are available.*

## Specifications

Type	VTA	VTB
Fluid medium	Air	
Operating pressure range	22 ~ 100psi (0.15 ~ 0.7MPa)	
Rated pressure supply	72.5psi (0.5MPa)	
Nozzle bore	ø0.5mm	ø0.4mm
Final vacuum	-25 in. Hg (-85kPa)	-23.6 in. Hg (-80kPa)
Suction flow	0.07scfm (2ℓ/min) [ANR]	
Operating temp. range	32 ~ 140°F (0~ 60°C) (no freezing)	
Volume resistance (※) (Anti-static type only)	Conductive ABS : 1 × 10 <sup>4</sup> Ω·cm, Conductive PA : 1 × 10 <sup>3</sup> Ω·cm, Conductive POM : 1 × 10 <sup>2</sup> Ω·cm, Conductive PBT : 1 × 10 <sup>3</sup> Ω·cm, Anti-static Coiling Tube : 1.4 × 10 <sup>3</sup> Ω·cm	
Air supply port (Tube O.D.)	ø4mm	

※ . Volume resistance value is a representative value from a material manufacturer and is not a guaranteed value.

## Model Designation of Air Pincette (Vacuum Pen) Package (Example)

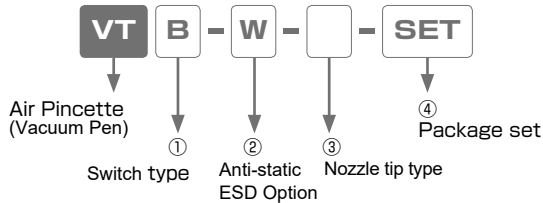

### ①. Switch type - On/Off

Code	A	B
Type	Close by a fingertip	Push Button Valve

### ②. Color (ESD Option)

Code	W	EG
Color (Spec.)	Light-gray	Black (ESD / Anti-static type)

### ③. Type of Nozzle tip

Code	No code	S
Type	Bended tip	Straight tip

### ④. SET : Package set (Only when ordering Package set)

■ A package set includes:

Item	Quantity	Details
Air pincette	1	VTA standard type. Color : Light-gray
		VTA anti-static type. Color : Black
		VTB standard type. Color : Light-gray
		VTB anti-static type. Color : Black
Header	1	Bended type for ø2 and ø4mm Straight type for ø2 and ø4mm
	1	Bended type for ø6 and ø8mm Straight type for ø6 and ø8mm
Vacuum pad (ø2, ø4, ø6, ø8mm)	1pc. per each size (Total 4pcs)	Material: Silicone rubber. Color: Translucent. For Standard type Material: Conductive Butadiene rubber (Low resistance type), Color: Black. For anti-static type
Coiling tube	1	Tube color: Milk white. For Light-gray vacuum pen
		Tube color: Black. For Black (ESD/anti-static) vacuum pen/air pincette.

## ■ Model Designation of Air Pincette (Vacuum Pen) Unit (Example) ■

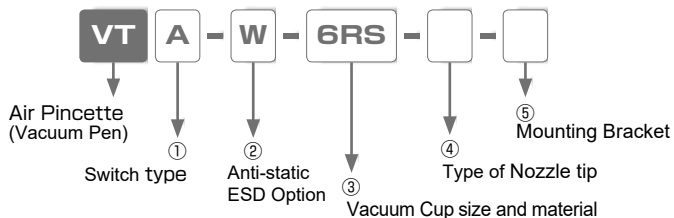

### ①. Switch type

Code	A	B
Type	No Push Button	Push Button Valve

### ②. Color (ESD Option)

Code	W	EG
Color (Spec.)	Light-gray	Black (Anti-static type)

### ③. Vacuum cup size and material

Code	Nitrile	1RN	2RN	4RN	6RN	8RN
	Silicone	1RS	2RS	4RS	6RS	8RS
	Conductive Butadiene (Low resistance)	1RE	2RE	4RE	6RE	8RE
	Pad size	ø1mm	ø2mm	ø4mm	ø6mm	ø8mm

※ . Electricity Conductive Butadiene rubber (Low resistance type) is available only when anti-static type is selected.

### ④. Type of Vacuum cup nozzle tip

Code	No code	S
Type	Bended tip	Straight tip

### ⑤. Mounting Bracket

Code	No code	H
Holder	without Bracket	with Bracket

## ■ Model Designation of Air Pincette (Vacuum Pen) body alone (Example) ■

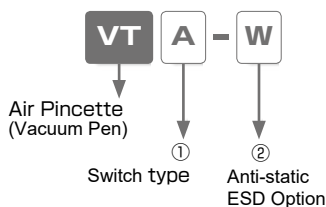

### ①. Switch type

Code	A	B
Type	No Push Button	Push Button Valve

### ②. Color (Anti-static/ESD option)

Code	W	EG
Color (Spec.)	Light-gray	Black (ESD / Anti-static type)

## ■ Vacuum cup and nozzle tip for light weight but larger work-piece

### ■ Model Designation of Header with Vacuum Cup ( Example )

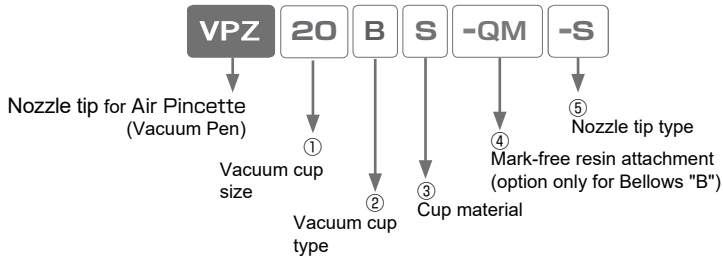

①, ②. Vacuum cup size and type

Cup type	Standard		Sponge	Bellows	Multi-Bellows	Soft	Soft bellows	Ultrathin object	Skidproof	Flat	Mark-free	Oval
	General	Deep										
Code	R	A	S	B	W	L	LB	P	K	F	Q	E
1	●P	-	-	-	-	-	-	-	-	-	-	2×4
2	●P	-	-	●P	-	-	-	-	-	-	-	3.5×7
3	●P	-	-	-	-	-	-	-	-	-	-	4×10
4	●P	-	-	●P	-	●S	-	-	-	-	-	5×10
6	●S	-	-	●S	-	●S	●S	-	-	-	-	6×10
8	●S	-	-	●S	-	●S	●S	●S	-	-	-	4×20
10	●M	-	●M	●M	●M	●S	●S	●S	●M	●M	●M	5×20
15	●M	●M	●M	●M	-	●S	●S	●S	-	●M	-	5×30
20	●M	●M	●M	●M	●M	●S	●S	●S	●M	●M	●M	6×20
25	●M	●M	●M	●M	-	-	-	-	-	●M	-	5×30
30	●M	●M	●M	●M	●M	●S	-	-	●M	●M	●M	6×20
35	-	-	●M	-	-	-	-	-	-	-	-	6×30
40	●M	●M	-	●M	●M	●S	-	-	●M	-	-	8×20
50	●M	●M	●M	●M	●M	-	-	-	●M	-	-	8×30

●P: Push-in mounting      ●S: Snap-on mounting      ●M: Screw mounting      -: not available

※ Oval cups are all snap-on mounting style

③. Cup material

Code	N	S	U	F	SE	E	NE	G	HN	EP	C	NH	FS	K	M	KE
Material	Nitrile	Silicone	Urethane	Fluoro rubber	ESD Silicone	ESD Butadien	ESD NBR	NBR-Japan food sanitation actcompl.	HNBR	EPDM	Chloroprene	Oil proof NBR	Fluoro Silicone	PEEK	POM	ESD PEEK
Vacuum cup type applicable	A,B,E, F,L,LB, P,R,W	A,B,E,F, K,L,LB, P,R,S,W	A,B,E,F, K,LB, P,R,W	A,B,E, F,K,P, R,W	B,E,F, L,R	E,R	A,B,E,F, K,L,LB, P,R,W	A,R,W	A,B,E, LB,R, W	A,B,E, LB, R,W	S	K	L,P	Q	Q	Q

④. Mark-free resin attachment material ( option for Bellows cups )

Code	-QK	-QM	-QKE
Material	PEEK	POM	ESD PEEK

⑤. Nozzle tip type

Code	No code	-S
Type	Bended tip	Straight tip

### ■ Model Designation of Nozzle tip only (Example)

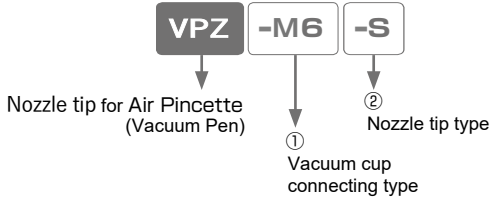

#### ①. Vacuum cup connecting code

Code	-H3	-T8	-M4	-M6	-T15	-T40
Connecting Style	Push-in (General ø1~ø4)	Snap-on (Standard & Ultrathin)	Screw-mount M4 thread	Screw-mount M6 thread	Snap-on (Soft & Soft bellows)	Snap-on (Soft & Soft bellows)

Cup type	Standard		Sponge	Bellows	Multi-Bellows	Soft	Soft bellows	Ultrathin object	Skidproof	Flat	Mark-free	Oval
	General	Deep										
Code	R	A	S	B	W	L	LB	P	K	F	Q	E
Cup size (ømm), D x W (mm) for oval type	Dia											
1	ø1	-H3	-	-	-	-	-	-	-	-	-	2×4
2	ø2	-H3	-	-H3	-	-	-	-	-	-	-	3.5×7
3	ø3	-H3	-	-	-	-	-	-	-	-	-	4×10
4	ø4	-H3	-	-H3	-	-T15	-	-	-	-	-	5×10
6	ø6	-T8	-	-T8	-	-T15	-T15	-	-	-	-	6×10
8	ø8	-T8	-	-T8	-	-T15	-T15	-T8	-	-	-	4×20
10	ø10	-M4	-	-M6	-M4	-M4	-T15	-T15	-T8	-M4	-M4	-M6
15	ø15	-M4	-M4	-M6	-M4	-	-T15	-T15	-T8	-	-M6	-
20	ø20	-M6	-M6	-M6	-M6	-M6	-T40	-T40	-T8	-M6	-M6	-M6
25	ø25	-M6	-M6	-M6	-M6	-	-	-	-	-	-M6	-
30	ø30	-M6	-M6	-M6	-M6	-M6	-T40	-	-	-M6	-M6	-M6
35	ø35	-	-	-M6	-	-	-	-	-	-	-	-
40	ø40	-M6	-M6	-	-M6	-M6	-T40	-	-	-M6	-	-
50	ø50	-M6	-M6	-M6	-M6	-M6	-	-	-	-M6	-	-

all -M6

#### ②. Nozzle tip type

Code	No code	-S
Type	Bended tip	Straight tip

## Construction (Fingertip operation type: VTA)

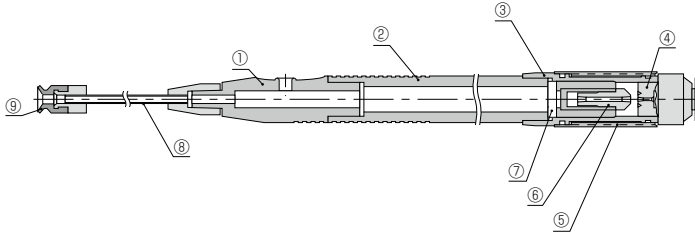

No.	Parts name	Material	
		Standard type	Anti-static type
①	Resin body A	ABS	Conductive ABS resin
②	Resin body B	PA	Conductive PA resin
③	Resin body C	POM	Conductive POM resin
④	Nozzle orifice Ass'y	—	
⑤	Cover	ABS	Conductive ABS resin
⑥	Diffuser	Nickel-plated brass	
⑦	Filter element	PVF	
⑧	Nozzle tip	Nickel-plated brass	
⑨	Vacuum cup	Nitrile rubber or Silicone rubber	Conductive Butadiene rubber (Low resistance type)

## Construction ( Push Button Valve: VTB)

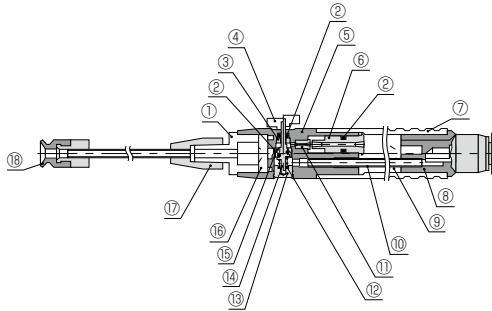

No.	Parts name	Material	
		Standard type	Anti-static type
①	Resin pad holder	ABS	Conductive ABS resin
②	O-ring	NBR	
③	O-ring support	Nickel-plated brass	
④	Push button	ABS	Conductive ABS resin
⑤	Resin body A	PBT	Conductive PBT resin
⑥	Diffuser	Nickel-plated brass	
⑦	Resin body B	PA	Conductive PA resin
⑧	Fitting body	PBT	Conductive PBT resin
⑨	Silencer element	PVF	
⑩	Pipe	Nickel-plated brass	
⑪	Nozzle orifice	Nickel-plated brass	
⑫	Spring	Stainless steel	
⑬	Valve guide	Nickel-plated brass	
⑭	Valve	Nickel-plated brass	
⑮	Valve ring	Nickel-plated brass	
⑯	Filter element	PVF	
⑰	Nozzle tip	Nickel-plated brass	
⑱	Vacuum cup	Nitrile rubber or Silicone rubber	Conductive Butadiene rubber (Low resistance type)

## How to use

### Air Pincette with no Push Button Valve: VTA

- Work-piece will be sucked by vacuum pad, while blocking the side hole during the supply of the compressed air 72.5psi (0.5MPa). Work-piece will be released by unblocking the side hole.

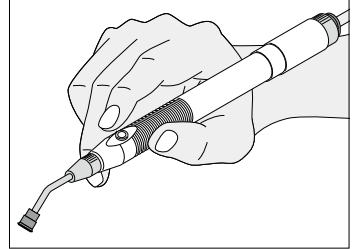

### Air Pincette with Push Button Valve: VTB

- Work-piece will be sucked by vacuum pad, while pressing the push button during the supply of the compressed air 72.5psi (0.5MPa). Work-piece will be released by releasing the button.

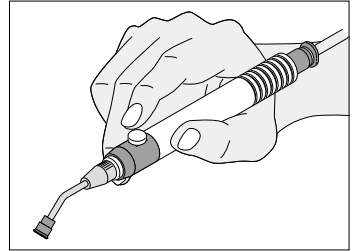

## Characteristics

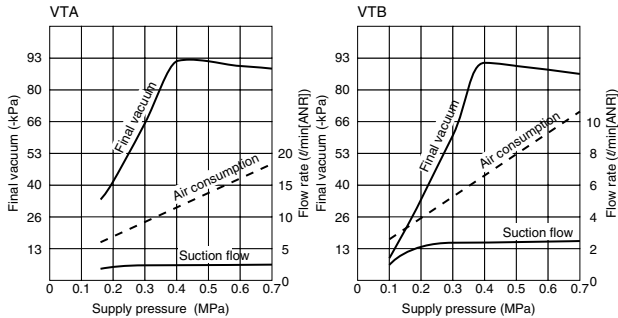

## ⚠ Detailed Safety Instruction

Before using PISCO products, be sure to read "Safety Instructions" and "Common Safety Instructions for Products Listed in This Catalog and "Common Safety Instructions for Vacuum Pad".

### Caution

- Do not use machine to operate the push button. The button may be damaged.
- Carry out the maintenance of the filter element periodically. The element is replaceable by detaching the ejector of VTA or the holder of VTB. There is a possibility of dropping the performance by the filter clogging.
- Silencer element of VTB is not replaceable.
- Use coiling tube for Air Pincette in order to minimize the load on Fitting.

### VTA Air Pincette (Vacuum Pen) with no Push Button Valve

RoHS compliant

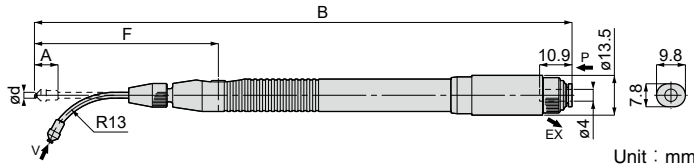

Unit : mm

Model code	Pad O.D. ød	A	B	F	Weight (g)	CAD file name
VTA-②-1R③-④-⑤	1	8	184.4	64.4	22	VTA_-1R_(S-)_
VTA-②-2R③-④-⑤	2	8	183.4	63.4	22	VTA_-2R_(S-)_
VTA-②-4R③-④-⑤	4	8	183.7	63.7	22	VTA_-4R_(S-)_
VTA-②-6R③-④-⑤	6	11	190.8	70.8	23	VTA_-6R_(S-)_
VTA-②-8R③-④-⑤	8	9.5	189.3	69.3	23	VTA_-8R_(S-)_

※ ② : Fill in the Color (Spec.) code, either W or EG.

※ ③ : Fill in the Cup rubber material code.

※ ④ : Fill in the Type of Nozzle tip code.

※ ⑤ : Fill in "H" when the mounting bracket is needed..

### VTB Air Pincette (Vacuum Pen) with Push Button Valve

RoHS compliant

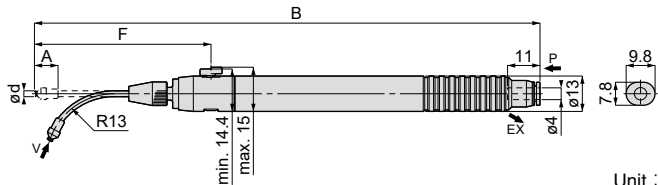

Unit : mm

Model code	Pad O.D. ød	A	B	F	Weight (g)	CAD file name
VTB-②-1R③-④-⑤	1	8	171.4	59.8	16	VTB_-1R_(S-)_
VTB-②-2R③-④-⑤	2	8	170.4	58.8	16	VTB_-2R_(S-)_
VTB-②-4R③-④-⑤	4	8	170.7	59.1	16	VTB_-4R_(S-)_
VTB-②-6R③-④-⑤	6	11	177.8	66.2	17	VTB_-6R_(S-)_
VTB-②-8R③-④-⑤	8	9.5	176.3	64.7	17	VTB_-8R_(S-)_

※ ② : Fill in the Color (Spec.) code, either W or EG.

※ ③ : Fill in the Cup rubber material code.

※ ④ : Fill in the Type of Nozzle tip code.

※ ⑤ : Fill in "H" when the mounting bracket is needed..

### VFUH Mounting Bracket

RoHS compliant

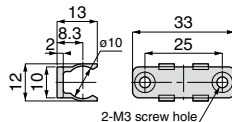

Unit : mm

Model code	Weight (g)
VFUH010P01	1.2

※ Color : Light-gray only.



## **VTA** Air Pincette (Vacuum Pen) Package with no Push Button Valve

RoHS compliant

Model code : VTA-**2**-SET



■ Air Pincette Package includes :

Item	Quantity	Details
Air pincette	1	VTA standard type. Color : Light-gray
		VTA standard type. Color : Blue
		VTA anti-static type. Color : Black
Pad holder for ø2 and ø4mm	1	R type for ø2 and ø4mm. Straight type for ø2 and ø4mm
Pad holder for ø6 and ø8mm	1	R type for ø6 and ø8mm. Straight type for ø6 and ø8mm
Vacuum pad (ø2, ø4, ø6, ø8mm)	1pc. per each size (Total 4pcs)	Material: Silicone rubber. Color: Translucent. For Standard type. Material: Conductive Butadiene rubber (Low resistance type). Color: Black. For anti-static type.
Coiling tube	1	Tube color: Milk white. For Light-gray air pincette.
		Tube color: Clear blue. For Blue air pincette.
		Tube color: Black. For Black (anti-static) air pincette.

## **VTB** Air Pincette (Vacuum Pen) Package with Push Button Valve

RoHS compliant

Model code : VTB-**2**-**3**-SET



■ Air Pincette Package includes :

Item	Quantity	Details
Air pincette	1	VTA standard type. Color : Light-gray
		VTA anti-static type. Color : Black
Pad holder for ø2 and ø4mm	1	R type for ø2 and ø4mm. Straight type for ø2 and ø4mm
Pad holder for ø6 and ø8mm	1	R type for ø6 and ø8mm. Straight type for ø6 and ø8mm
Vacuum pad (ø2, ø4, ø6, ø8mm)	1pc. per each size (Total 4pcs)	Material: Silicone rubber. Color: Translucent. For Standard type. Material: Conductive Butadiene rubber (Low resistance type). Color: Black. For anti-static type.
Coiling tube	1	Tube color: Milk white. For Light-gray air pincette.
		Tube color: Black. For Black (anti-static) air pincette.

### UL Coiling Tube for Air Pincette (Vacuum Pen)

Unit : mm



Model code	Weight (g)	Applicable Air Pincette unit
UL04-2-W	15	VTA-W-3, VTB-W-3
UEL04-2-B	15	VTA-EG-3, VTB-EG-3

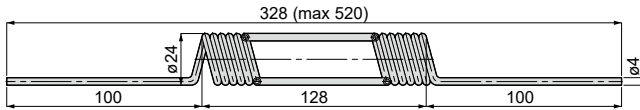

#### Replacement of Element: VTA

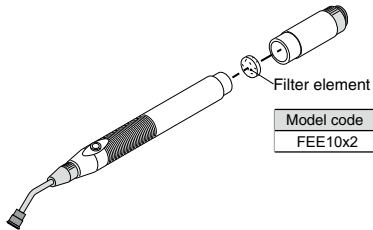

Model code  
FEE10x2

#### Replacement of Element: VTB

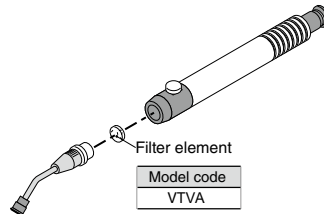

Filter element  
Model code  
VTVA

#### Replacement of Nozzle Tip (for Standard vacuum pen)

##### Bended tip



Bended Header Model Code	Applicable Pad size
VPZ-H3	ø1, ø2, ø3, ø4mm
VPZ-T8	ø6, ø8mm

##### Straight Tip



Straight Header Model Code	Applicable Pad size
VPZ-H3-S	ø1, ø2, ø3, ø4mm
VPZ-T8-S	ø6, ø8mm

Dimensions for Nozzle tip for larger suction cups

■ Bended nozzle tips

**VPZ-M4**

Weight : 4.6g

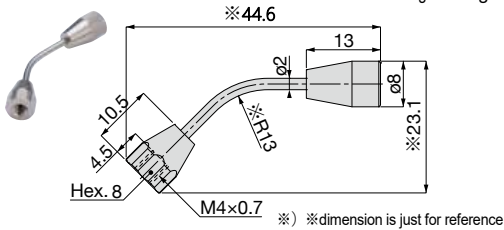

**VPZ-M6**

Weight : 5.0g

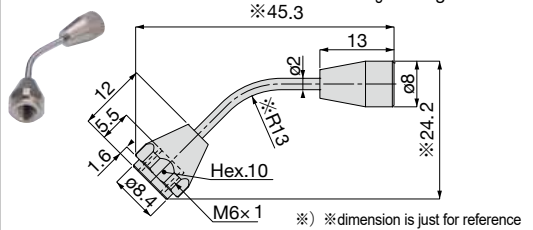

**VPZ-T15** (for soft type and soft bellows)

Weight : 5.0g

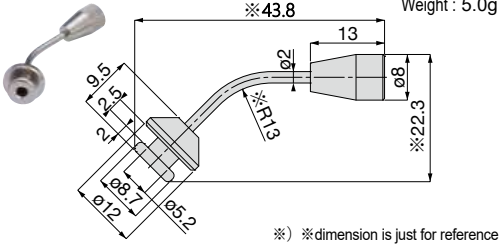

**VPZ-T40** (for soft type bellows)

Weight : 5.3g

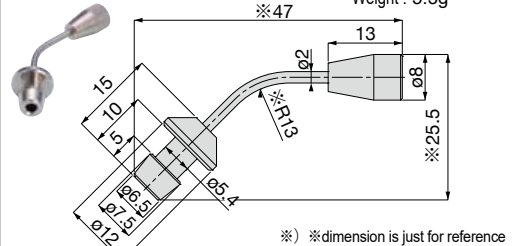

■ Straight nozzle tips

**VPZ-M4-S**

Weight : 4.6g

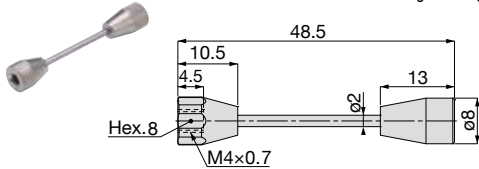

**VPZ-M6-S**

Weight : 5.0g

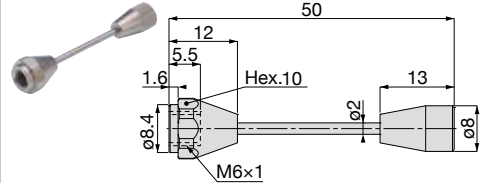

**VPZ-T15-S** (for soft type and soft bellows)

Weight : 5.0g

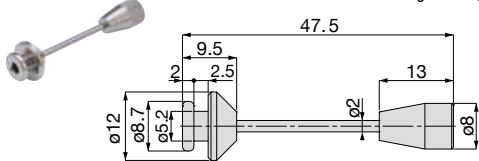

**VPZ-T40-S** (for soft type and soft bellows)

Weight : 5.3g

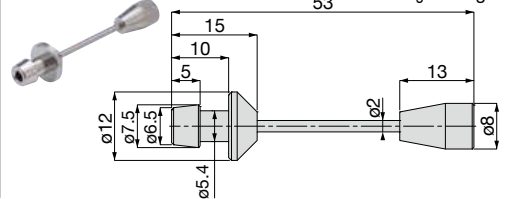

Model	Price (\$)	Cup connecting code
VPZ-M4	4.55	-M4
VPZ-M4-S	4.55	-M4
VPZ-T15	4.55	-T15
VPZ-T15-S	4.55	-T15

Model	Price (\$)	Cup connecting code
VPZ-M6	5.00	-M6
VPZ-M6-S	5.00	-M6
VPZ-T40	5.00	-T40
VPZ-T40-S	5.00	-T40



# Vacuum Pad Selection Guide

Selection Guide 1 ▶ Select the diameter of vacuum pad from the formula ① and chart of the theoretical suction force ②

The theoretical suction force is determined from pad area and vacuum level. Calculated value is for reference only, so carry out the evaluation under an actual operating condition. The theoretical suction force is calculated under a static condition. Obtain an enough margin, considering the weight of a work-piece and acceleration of lifting, pause and rotary movement. Enough room is needed in deciding a number of pads and arrangement position.

### ① Calculation by formula

$$W = \frac{C \times P}{101} \times 10.13 \times f$$

W : Suction force (N)

C : Pad area (cm<sup>2</sup>)

P : Vacuum level (-kPa)

f : Safety factor Horizontal lifting (refer to the right fig.) ▶ 1/4

Vertical lifting (refer to the right fig.) ▶ 1/8

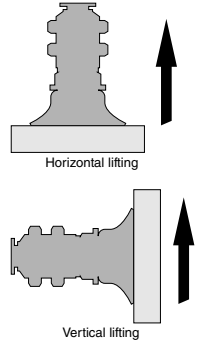

\*1. Refer to the following chart for Sponge Series.(Internal diameter is used for calculation)

\*2. Refer to the following chart for Flat Series.(Pad grooves are used for calculation)

\*3. As for Bellows, Multi-Bellows, Soft, Soft Bellows and Ultrathin Series, their theoretical suction force may exceed the strength of pad itself, depending on the vacuum level. Carry out the evaluation under an actual operating condition.

### ② Chart of the theoretical suction force (Add safety factor to values from the chart)

Standard / Bellows / Multi-bellows / Soft / Soft bellows / Skidproof / Ultrathin / Mark-free (\*)

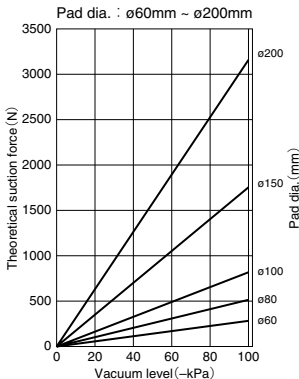
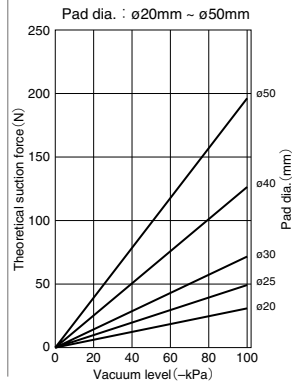
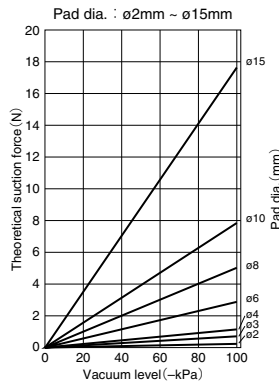
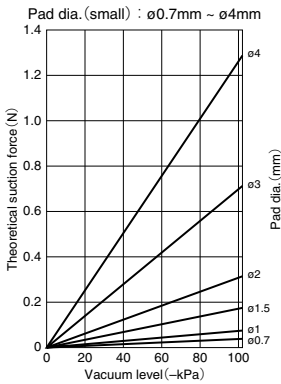

\*. Some sizes are not available for some pad series. Refer to the following size list.

Pad type	Standard	Bellows	Multi-bellows	Soft	Soft bellows	Skidproof	Ultrathin	Mark-free
ø0.7-ø3	●	—	—	—	—	—	—	—
ø4	●	—	—	●	—	—	—	—
ø6	●	●	—	●	●	—	—	—
ø8	●	●	—	●	●	●	●	—
ø10	●	●	●	●	●	●	●	●
ø15	●	●	—	●	●	—	●	—
ø20	●	●	●	●	●	●	●	●
ø25	●	●	—	—	—	—	—	—
ø30	●	●	●	●	—	●	—	●
ø40	●	●	●	●	—	●	—	—
ø50	●	●	●	—	—	●	—	—
ø60	●	●	—	—	—	—	—	—
ø80	●	●	—	—	—	—	—	—
ø100	●	●	—	—	—	—	—	—
ø150	●	—	—	—	—	—	—	—
ø200	●	—	—	—	—	—	—	—

● indicates that pad size is available.

**Sponge pad**

Pad dia. :  $\phi 10\text{mm} \sim \phi 100\text{mm}$

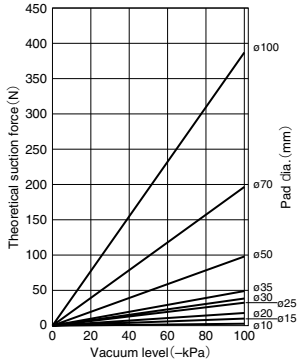

**Flat pad**

Pad dia. :  $\phi 10\text{mm} \sim \phi 30\text{mm}$

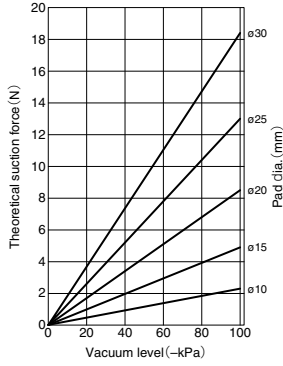

**Oval pad**

Pad size :  $2 \times 4\text{mm} \sim 8 \times 30\text{mm}$

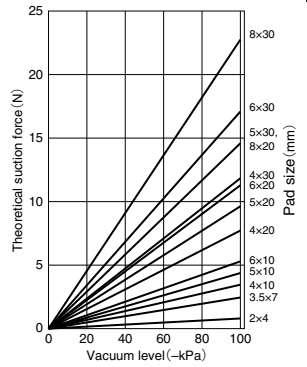

mm



## Selection Guide 2 ▶ Select a vacuum pad type according to a work-piece

Please select suitable pads for your application from the following.

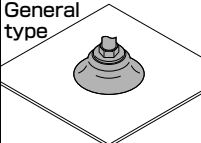
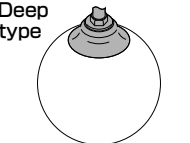
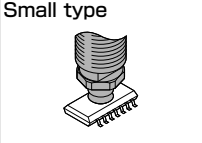
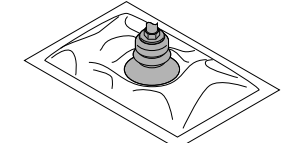
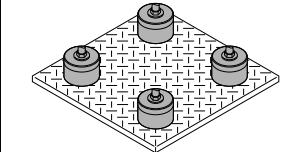
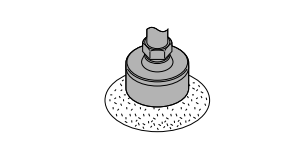
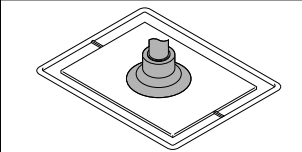
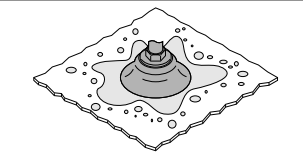
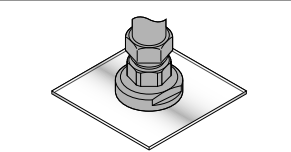
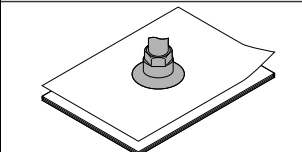
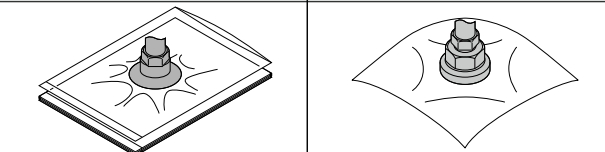
Standard Series		Bellows / Multi-bellows Series	
<b>General type</b> 	<b>Deep type</b> 	<b>Small type</b> 	
Thick & flat work-piece	Round fruit or ball (*1)	Small work-piece or semiconductor product	Food package
Sponge Series		Oval Series	
			
Exterior wall panel, pebble, seashell		Long work-piece (e.g. circuit board and semiconductor product)	
Soft / Soft bellows Series	Skidproof Series	Mark-free Series	
			
Molded parts / Fragile work-piece	Greasy work-piece such as pressed parts	LCD glass / in Painting process / semiconductor	
Ultrathin Series		Flat Series	
			
Thin work-piece such as paper or plastic bag		Thin work-piece such as sheet or plastic bag	

\*1. The table below is a reference for the vacuum pad deep type and the size of round work-piece.

Spherical dia. : S (mm)	ø20	ø30	ø40	ø50	ø80	ø100	ø120	ø160	ø200
Pad dia. : d (mm)	ø15	ø20	ø25	ø30	ø40	ø50	ø60	ø80	ø100

\*2. Refer to the previous page for pad dia. selection except deep type. Refer to the next page for the characteristics of pad materials.

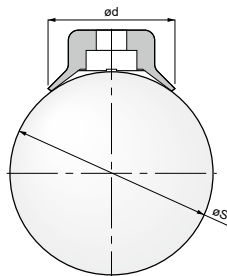

## Selection Guide 3 ▶ Select a vacuum pad material from an application

Please select the suitable material from the table.

Item	Pad material	Nitrile rubber	NBR Suited for the food sanitation act. (Japan)	HNBR	Silicone rubber	Conductive Silicone rubber	Urethane rubber	Fluoro rubber	Fluorosilicone rubber	EPDM	Conductive Butadiene rubber (Low resistance type)	Conductive NBR (low resistance)	Chloroprene rubber (For Sponge type)	Silicone rubber (For Sponge Type)	
	Material code	N, NH(*1)	G	HN	S	SE	U	F	FS	EP	E	NE	—	S	
Application		Cardboard Plywood Metal plate Food-related Other general work	Cardboard Plywood Metal plate Food-related Other general work In use under a low ozone concentration environment	Semiconductors Taking out molded parts Thin work-piece Food-related	Cardboard Plywood Metal plate	Chemical environment High temp. work-pieces	Taking out molded parts	Application that requires light-resistant or ozone-proof in use under in the moisture-containing atmosphere	General parts of semiconductors	Semiconductors	Uneven work-piece	Uneven work-piece Food-related			
Pad color		Black	Gray	Black	Translucent	Black	Blue	Gray	Salmon	Black	Black	Black	Black	Salmon	
Physical Properties	Surface hardness (Shore A)	Standard	50°~80°	60°~70°	50°~70°	50°	60°	55°~70°	60°~70°	—	50°~70°	70°	60°~70°	—	—
		Bellows	50°	—	50°	50°	60°	55°	60°	—	50°	—	60°	—	—
		Multi-bellows	50°	50°	50°	50°	—	55°	50°	—	50°	—	60°	—	—
		Oval	40°~50°	—	50°	40°~50°	50°~60°	55°(*2)	50°(*2)	—	50°	70°	70°	—	—
		Soft	40°	—	—	40°	60°	—	—	40°	—	—	50°	—	—
		Soft bellows	40°	—	50°	40°	—	55°	—	—	50°	—	60°	—	—
		Skidproof	50°	—	—	50°	—	55°	60°	—	—	—	60°	—	—
	Ultrathin	40°	—	—	40°	—	55°	50°	40°	—	—	60°	—	—	
	Flat	60°	—	—	40°	40°	50°	50°	—	—	—	60°	—	—	
	Highest operating temp.		110°C	140°C	180°C	180°C	230°C	180°C	150°C	100°C	110°C	80°C	180°C		
	Lowest operating temp.		-30°C	-30°C	-40°C	-20°C	-10°C	-50°C	-40°C	-50°C	-30°C	-45°C	-40°C		
	Weatherability		△	○	◎	○	○	○	◎	○	△	○	◎		
	Ozone-proof		×	○	◎	◎	◎	◎	◎	◎	×	×	◎	◎	
	Acid-resistance		△	△	○	×	◎	◎	◎	△	△	△	○		
	Alkaline-resistance		○	○	◎	◎	×	×	◎	◎	○	○	◎	◎	
Oil resistance (Gasoline oil)		◎	◎	△	△	◎	◎	△	×	×	◎	×	△		
Oil resistance (Benzene/toluene)		△	×	△	△	◎	◎	×	×	×	△	△	△		
Volume resistance		—	—	—	Max.10 <sup>11</sup> Ω·cm	—	—	—	—	—	Max.2000Ω·cm	Max.2000Ω·cm	—	—	

Legend ◎ : Best  
 ○ : Suitable  
 △ : Good  
 × : NG

\*1. Material code "NH" is only applicable to Skidproof Series.

\*2. It does not apply to pad size: 4×30mm.

Note 1) The above "Physical Properties" shows the data of general synthetic rubbers.

Note 2) The highest / lowest operating temp. are for momentary usage. Carry out durability evaluation in case of continuous usage under the highest / lowest operating temp.



Please select the suitable vacuum pad resin material from the table.

Item	Pad material		PEEK	POM	Conductive PEEK
	Material code	Mark free series Resin attachment for Bellows series	K -QK	M -QM	KE -QKE
Application			Semiconductor/ Manufacturing machine for liquid crystal	General production line Food-related machine Packaging machine	Semiconductors/ Manufacturing machine for liquid crystal Electronic components
Pad color			Natural (ivory)	White	Black
Physical Properties	Highest operating temp.		250°C	95°C	250°C
	Lowest operating temp.		-50°C	-60°C	-50°C
	Weatherability		○	×	○
	Acid-resistance		○	×	○
	Alkaline-resistance		○	△	○
	Self-lubricity		○	○	○
	Abrasion-resistance		○	○	○
Volume resistance			-	-	10 <sup>5</sup> -10 <sup>6</sup> Ω·cm

Legend ⇨ ○ : Best  
 ○ : Suitable  
 △ : Good  
 × : NG

Note 1) The above "Physical Properties" shows the data of pad resin material only. The holder of Mark-free Series is not included.

Note 2) The above "Physical Properties" shows the data of resin attachment only. The pad rubber is not included.

Note 3) The above "Physical Properties" shows general properties of resin materials and not a guaranteed value. Carry out the necessary evaluation under an actual operating condition.

Note 4) The highest / lowest operating temp. is for momentary usage. Carry out durability evaluation in case of continuous usage under the highest / lowest operating temp.

Note 5) Volume resistance is a representative value from the material manufacture, and not a guaranteed value.

### To prevent dust from getting into the pad holder.

Install a vacuum filter pad direct mounting type between a vacuum pad and a holder.

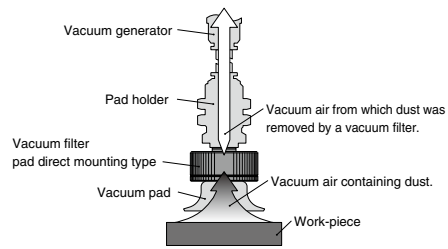

### To operate several vacuum pads by single vacuum source.

Installing a fall prevention valve between a vacuum pad and a holder prevents the troubles like system break down, minimizing the vacuum drop of the whole system automatically by reducing suction flow of the part where the work-piece falls from the vacuum pad (within the range not causing any problem), or no work-piece is to be sucked.

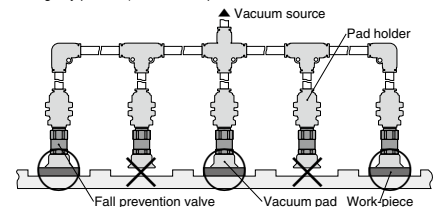



# Reference Guide for Vacuum Pad

## Impact on pad

Avoid an impact or a large force on a vacuum pad, when it is pressed against a work-piece. It may cause deformation, crack or abrasion at an early stage of use. Adjust the pad position so that the lip of pad touches lightly on a work-piece. Especially a small type of vacuum pad should be positioned precisely.

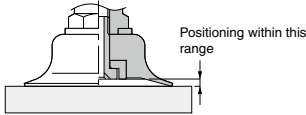

## Porous or perforated work-piece

Since the suction of a porous work-piece causes a drop of suction force, select the proper specifications of vacuum system and secure a larger effective cross-section area of the piping. Selecting a small type of vacuum pad is one of solutions to reduce the air leakage.

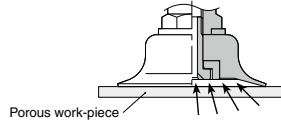

## Large and wide flat plate work-piece

When lifting large size of glass board or circuit board, work-piece may bend by the lifting acceleration or the self-weight. Select a proper size of pad and positioning, considering an enough margin of suction force.

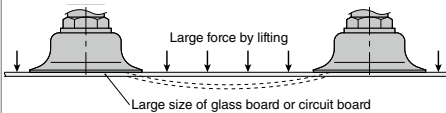

## Lifting work-piece, sucking the both side of it

Since all vacuum pad holders are designed for horizontal lifting, consider the strength of holders and pads.

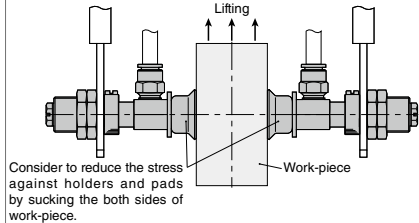

## Soft work-piece

When soft work-pieces such as plastic bags, papers or thin boards are sucked, work-pieces can be deformed or shrunk by vacuum suction (Figure-1). Select smaller vacuum pads and reduce the vacuum pressure. Smaller vacuum pads are suitable for plastic bags and papers. When plastic / paper bags are opened by using vacuum pads, shift the center of two vacuum pads slightly in order to open them easily as Figure-2 shows.

● Figure-1

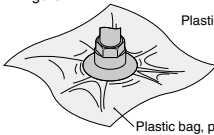

● Figure-2

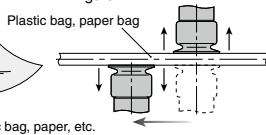

## Work-piece with different heights

Select Long Stroke Series for work-pieces having different heights, or piled-up work-pieces. Its stroke can absorb the difference in height.

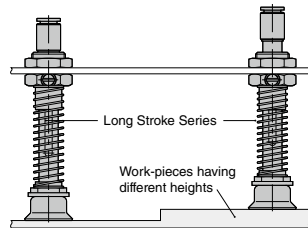

## Inclined work-piece

Select Free Holder for an inclined work-piece.

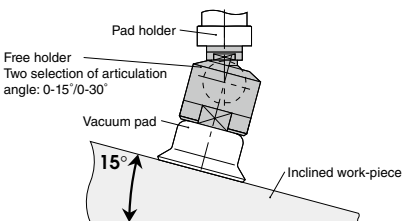

## Conveyance with rotary movement

When vacuum pad is fixed with a screw and has a rotary movement, the pad may drop due to the loosened screw. Pay special attention when the vacuum location of work-piece is off the center of work-piece gravity.

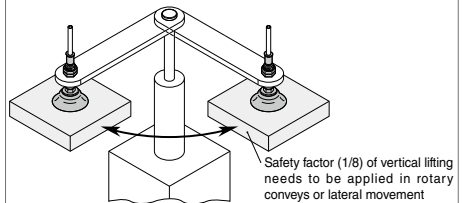



## ■ Pad dia. list by pad type and material

Pad material		N : Nitrile rubber								
Pad type	Standard			Bellows	Multi-Bellows	Soft	Soft bellows	Ultrathin	Flat	
	General type	Deep type	Small type							
Pad dia. (mm)	ø0.7			●						
	ø1	●		●						
	ø1.5			●						
	ø2	●		●						
	ø3	●		●						
	ø4	●		●			●			
	ø6	●			●		●	●		
	ø8	●			●		●	●	●	
	ø10	●			●	●	●	●	●	
	ø15	●	●		●	●	●	●	●	
	ø20	●	●		●	●	●	●	●	
	ø25	●	●		●				●	
	ø30	●	●		●	●	●		●	
	ø40	●	●		●	●	●			
	ø50	●	●		●	●				
	ø60	●	●		●					
	ø80	●	●		●					
	ø100	●	●		●					
ø150	●									
ø200	●									

※ ● : available

Pad material		S : Silicone rubber									
Pad type	Standard			Bellows	Multi-Bellows	Soft	Soft bellows	Flat	Skidproof	Ultrathin	Sponge
	General type	Deep type	Small type								
Pad dia. (mm)	ø0.7			●							
	ø1	●		●							
	ø1.5			●							
	ø2	●		●							
	ø3	●		●							
	ø4	●		●			●				
	ø6	●			●		●	●			
	ø8	●			●		●	●		●	
	ø10	●			●	●	●	●	●	●	●
	ø15	●	●		●	●	●	●	●	●	●
	ø20	●	●		●	●	●	●	●	●	●
	ø25	●	●		●			●			●
	ø30	●	●		●	●	●		●		●
	ø35										●
	ø40	●	●		●	●	●			●	
	ø50	●	●		●	●				●	●
	ø60	●	●		●						
	ø70										●
ø80	●	●		●							
ø100	●	●		●						●	
ø150	●										
ø200	●										

※ ● : available

Pad material		U : Urethane rubber							
Pad type	Standard			Bellows	Multi-Bellows	Soft bellows	Skidproof	Ultrathin	Flat
	General type	Deep type	Small type						
Pad dia. (mm)	ø0.7			●					
	ø1	●		●					
	ø1.5			●					
	ø2	●		●					
	ø3	●		●					
	ø4	●		●					
	ø6	●			●		●		
	ø8	●			●		●		●
	ø10	●			●	●	●	●	●
	ø15	●	●		●	●	●	●	●
	ø20	●	●		●	●	●	●	●
	ø25	●	●		●				●
	ø30	●	●		●	●		●	●
	ø40	●	●		●	●		●	
	ø50	●	●		●	●		●	
	ø60	●	●		●				
	ø80	●	●		●				
ø100	●	●		●					
ø150	●								
ø200	●								

※ ● : available

Pad material		F : Fluoro rubber							G : NBR Suited for the food sanitation act. (Japan)				
Pad type	Standard			Bellows	Multi-Bellows	Skidproof	Ultrathin	Flat	Standard			Multi-Bellows	
	General type	Deep type	Small type						General type	Deep type	Small type		
Pad dia. (mm)	ø0.7			●								●	
	ø1	●		●					●			●	
	ø1.5			●								●	
	ø2	●		●					●			●	
	ø3	●		●					●			●	
	ø4	●		●					●			●	
	ø6	●			●				●				
	ø8	●			●			●	●				
	ø10	●			●	●	●	●	●				●
	ø15	●	●		●	●	●	●	●	●			●
	ø20	●	●		●	●	●	●	●	●	●		●
	ø25	●	●		●			●	●	●	●		
	ø30	●	●		●	●	●		●	●	●		●
	ø40	●	●		●	●	●		●	●	●		●
	ø50	●	●		●	●	●			●	●		●
	ø60	●	●		●								
	ø80	●	●		●								
ø100	●	●		●									
ø150	●												
ø200	●												

※ ● : available



# Vacuum Sucking Pen

Pad material		SE : Conductive Silicone rubber				E : Conductive Butadiene rubber (Low resistance type)	S : Chloroprene rubber	NH : Oilproof NBR	
Pad type	Standard		Bellows	Soft	Flat	Standard		Sponge	Skidproof
	General type	Small type				General type	Small type		
Pad dia. (mm)	ø0.7		●				●		
	ø1	●	●				●	●	
	ø1.5		●					●	
	ø2	●	●				●	●	
	ø3	●	●				●	●	
	ø4	●	●		●		●	●	
	ø6	●		●	●		●		
	ø8	●		●	●		●		
	ø10	●		●	●	●	●		●
	ø15	●		●	●	●	●	●	
	ø20	●		●	●	●	●	●	●
	ø25	●		●	●	●	●	●	
	ø30	●		●	●	●	●	●	●
	ø35							●	
	ø40	●		●	●		●		●
	ø50	●		●			●	●	●
	ø60	●		●					
	ø70							●	
ø80	●		●						
ø100	●		●				●		
ø150	●								
ø200	●								

※ . ● : available

Pad material		NE : Conductive NBR (low resistance)								
Pad type	Standard			Bellows	Multi-Bellows	Soft	Soft bellows	Skidproof	Ultrathin	Flat
	General type	Deep type	Small type							
Pad dia. (mm)	ø0.7			●						
	ø1	●		●						
	ø1.5			●						
	ø2	●		●						
	ø3	●		●						
	ø4	●		●			●			
	ø6	●			●		●	●		
	ø8	●			●		●	●	●	
	ø10	●			●	●	●	●	●	●
	ø15	●	●		●		●	●	●	●
	ø20	●	●		●	●	●	●	●	●
	ø25	●	●		●					●
	ø30	●	●		●	●	●		●	●
	ø40	●	●		●	●	●		●	
	ø50	●	●		●	●			●	
	ø60	●	●		●					
	ø80	●			●					
	ø100	●	●		●					
ø150	●									
ø200	●									

※ . ● : available

Pad material	HN : HNBR						EP : EPDM						FS : Fluorosilicone rubber	
	Standard			Bellows	Multi-Bellows	Soft bellows	Standard			Bellows	Multi-Bellows	Soft bellows	Soft	Ultrathin
	General type	Deep type	Small type				General type	Deep type	Small type					
Pad dia. (mm)	ø0.7			●					●					
	ø1	●		●				●	●					
	ø1.5			●					●					
	ø2	●		●				●	●					
	ø3	●		●				●	●					
	ø4	●		●				●	●				●	
	ø6	●			●			●		●		●	●	
	ø8	●			●			●		●		●	●	●
	ø10	●			●	●		●		●	●	●	●	●
	ø15	●	●		●	●		●	●	●	●	●	●	●
	ø20	●	●		●	●		●	●	●	●	●	●	●
	ø25	●	●		●			●	●	●				
	ø30	●	●		●	●		●	●	●	●		●	
	ø40	●	●		●	●		●	●	●	●		●	
	ø50	●	●		●	●		●	●	●	●			
	ø60	●	●		●			●	●	●				
	ø80	●	●		●			●	●	●				
	ø100	●	●		●			●	●	●				
ø150	●						●							
ø200	●						●							

※ ● : available

Pad material	N	S	U	F	SE	E	NE	HN	EP	
	Nitrile rubber	Silicone rubber	Urethane rubber	Fluoro rubber	Conductive Silicone rubber	Conductive Butadiene rubber (Low resistance type)	Chloroprene rubber	HNBR	EPDM	
Pad type	Oval									
Pad size (mm)	2x4	●	●	●	●	●		●	●	●
	3.5x7	●	●	●	●	●		●	●	●
	4x10	●	●	●	●	●	●	●	●	●
	4x20	●	●	●	●	●	●	●	●	●
	4x30	●	●			●	●	●	●	●
	5x10	●	●	●	●	●	●	●	●	●
	5x20	●	●	●	●	●	●	●	●	●
	5x30	●	●	●	●	●	●	●	●	●
	6x10	●	●	●	●	●	●	●	●	●
	6x20	●	●	●	●	●	●	●	●	●
	6x30	●	●	●	●	●	●	●	●	●
	8x20	●	●	●	●	●	●	●	●	●
8x30	●	●	●	●	●	●	●	●	●	

※ ● : available

Pad material	K : PEEK	M : POM	KE : Conductive PEEK	Q2K : PEEK	Q2M : POM	Q2KE : Conductive PEEK
	Mark free			Resin attachment for Bellows series		
Pad size (mm)	ø10	●	●	●	●	●
	ø15				●	●
	ø20	●	●	●	●	●
	ø25				●	●
	ø30	●	●	●	●	●

※ ● : available